

**Pazon**  
IGNITIONS WITH THE 7½ YEAR WARRANTY

# Altair™ Electronic Ignition System for

**TRIUMPH** *BSA*

3 Cylinder Motorcycles



System# AL3

## Altair Electronic Ignition System for

- **Triumph Trident T150, T150V, T160 X75 Hurricane**
- **BSA A75R Rocket 3**

## Features

- **Fully digital design**
- **Compact digital ignition module (fully encapsulated) - module size: 80x40x20mm**
- **Fully mapped ignition timing and programmed coil energy control**
- **Electronic tachometer drive output**
- **Reliable and rugged hall-effect sensor includes on-board static timing light for easy setting of ignition timing**
- **Three 3 volt ignition coils included - directly replaces original 12 or 6 volt coils**
- **Very low voltage operation - ideal for electric starters and kick starters**
- **Extremely efficient operation: high spark energy and low power consumption**
- **Wasted spark system for simplicity of fitting, wiring and timing**
- **Very low maintenance**
- **Improved starting, idling and overall performance**
- **Covered by manufacturer's 7½ Year Warranty**

## System Contents

- **Ignition module (black rectangular unit with wiring)**
- **Digital hall-effect trigger unit (circular printed circuit board with components)**
- **Electroplated steel rotor, ¼" UNF cap head screw + flat washer**
- **Three 3 volt ignition coils**
- **Three NGK 5K suppressor plug caps**
- **Two black ignition coil link wires**
- **Adhesive cable tie mounting base (for ignition module)**
- **Crimp terminal connectors & insulators**
- **Black sleeving (for protecting wiring)**
- **Large & small cable ties**

## Important notes

**Warning: this ignition system produces very high voltages.  
Always switch the ignition off before working on the bike.**

- This system is designed to give optimum results with the 3 volt ignition coils supplied.
- 5k suppressor/resistor plug caps (as supplied) should be used with this system. Resistor spark plugs can also be used. Attempting to run the system without any suppressors will result in excessive radio frequency interference (r.f.i.), which may cause misfiring, bad running, loss of ignition and interference with other electronic/electrical items.
- For reliability, copper or steel plug wires (h.t. leads) should be used. Carbon fibre plug wires should be avoided.
- If you are using the correct type/grade of spark plugs, you do not need to change them when running with this system. Standard plug types B8ES/B8EV (NGK) or W24ES-U/W24ES-ZU (Denso) or equivalent. Recommended plug gap range: 0.028"-0.035" (0.7-0.9mm).
- This is a wasted spark system, therefore all plugs spark at the same time, every 240° of crankshaft rotation.
- All electrical connections should be made using good quality crimped or soldered connectors. Twisted wires will not give satisfactory results.
- Wiring should be cut to the correct length. Excess wire should not be coiled up, as this can affect the correct operation of the system.
- If electric welding is to be carried out on the bike, the ignition module should be disconnected and removed.

## Installation

1. All connections must be of the highest quality, using crimped or soldered connectors. Twisted wires will not give satisfactory operation.
2. Open the seat to gain access to the ignition coils and wiring.
3. Remove the left hand side battery cover.
4. For safety, disconnect the battery by removing the fuse from the negative battery terminal (positive terminal if the electrics are negative ground).
5. Undo the contact-breaker cover and remove the complete contact-breaker assembly and backing plate. Disconnect the three wires.
6. Remove the complete auto-advance unit. If stuck it can be removed from its taper by using a puller or by inserting a small piece of steel rod down the centre and tapping it around until it frees from the taper.
7. Disconnect and remove the black-red, black-white and black-yellow wires from the ignition coils and condensers. These wires run through the wiring harness down to the contact-breaker housing and are no longer required. The condensers are no longer required and can be removed. They should not be connected to the electronic ignition system.
8. Remove the white-yellow wires from the negative terminals of the three ignition coils (positive terminals if negative ground electrics).
9. Pull the plug caps from the spark plugs and remove the three plug wires from the coils. Keep the plug wires for later use.
10. Remove the three original ignition coils. If the coils are stuck in their mountings, apply penetrating oil and, by removing the battery, the coils can be reached from below and worked out.
11. Fit the new (supplied) ignition coils in place of the originals.
12. Screw the new (supplied) suppressor plug caps onto the original plug wires.
13. Refit the plug wires to the ignition coils. Mount the ignition module in a convenient place, away from

sources of heat. Allow some air space around the module. Do not wrap in foam rubber or similar. A thin sheet of rubber can be placed between the module and frame, to minimise movement and vibration effects.

14. Secure the module to the frame using one or more large cable ties. An adhesive cable-tie mounting base is provided, which can be affixed to the side or back of the module case, and the cable tie passed through and around the module and frame.
15. Remove the timing side spark plug. Turn the engine over until compression is felt by placing a finger over the plug hole.
16. Remove the triangular inspection plate to expose the alternator rotor. Slowly rotate the engine forward until the first timing mark is aligned with the reference pointer. This is the full advance timing mark (standard is 38° BTDC), which is identified in the Owners Manual. The right hand cylinder is now at the full advance timing position. The timing marks on the alternator are 120° apart, but only every 240° is any one cylinder on compression. So it is possible to set the ignition to fire on a timing mark but off compression.
17. Take the ignition trigger (round green printed circuit board) and pass a small cable-tie through the set of holes in front of the 3-way connector terminal block; leave unfastened at this stage. Fit the trigger assembly (connector block facing outwards) into the contact-breaker housing, using the original pillar fixings. Finger tighten so that the trigger can be rotated by hand. Rotate the trigger fully counter-clockwise on its adjustment slots, as per fig 3.
18. Pass the steel rotor through the centre hole in the trigger, and fit into the taper (from which the auto-advance unit was removed). Then, **without turning the engine**, position the rotor so that one of the three slots is positioned relative to the centre of the black sensor on the trigger, as shown in fig 3. Pass the ¼" UNF cap head screw and washer through the centre of the rotor and into the thread in the end of the camshaft. Recheck the rotor position and tighten the cap head screw using a 3/16" allen/hex key. The rotor centre thread (metric M8) is provided for attaching a puller, if the rotor should need to be removed for engine servicing, etc.

## Wiring                      See wiring diagrams on pages 6 & 7

1. The ignition trigger wires are coloured: White-Black, Violet-Red and White-Red. Allowing some slack in the cable, route these wires & sleeving from the ignition module down to the ignition trigger assembly in the contact-breaker housing. If passing through holes in metalwork use grommets and/or sleeving to protect the wiring. Route the wires to the 3-way connector terminal block. Allowing some movement in the wiring (allowing for trigger movement to set the ignition timing), cut the wiring and sleeving to length. Carefully strip back 4-5mm of insulation from the ends of the three wires. Insert the stripped ends of the three wires into the connector terminal block (from left to right) as follows: White-Black, Violet-Red & White-Red. See fig 2, page 10.
2. Tighten the three screws with a small screwdriver. Secure the sleeved wires to the trigger plate with a small cable-tie, using the set of holes provided in front of the connector block. Cut off the excess from the end of the tie.
3. Take one of the black ignition coil link wires and connect the positive (+) terminal of coil#1 to the negative (-) terminal of coil#2. Take the other black coil link wire and connect the positive (+) terminal of coil#2 to the negative (-) terminal of coil#3. All three ignition coils produce sparks at the same time. Therefore it is not important which coil is taken as #1, provided the three coils are connected as described here and as shown in the wiring diagrams.
4. Take the violet wire from the ignition module, cut to length and fit a female crimp connector and insulator to the end of the wire. Connect the violet wire to the negative (-) terminal of coil#1.
5. Take the red wire from the ignition module, cut to length and fit a piggyback female crimp connector and insulator to the end of the wire. Connect the red wire to the positive (+) terminal of coil#3.

For **NEGATIVE GROUND** electrics, *goto step 8*.

For **POSITIVE GROUND** electrics (standard):

6. Remove the red wire going to the grounding terminal on the condenser unit. Reconnect this wire onto the spade terminal of the piggyback connector on ignition coil#3 positive (+) terminal. Alternatively a new red grounding wire can be made to suit. This would be connected from ignition coil#3 positive (+) terminal to a good grounding point on the frame or directly to the battery positive (+) terminal.
7. Take the black wire from the ignition module, cut to length and fit an insulator and male spade crimp connector to the end. Connect the black wire to any one of the three white-yellow wires previously removed from the ignition coils. If desired, an in-line fuse can be fitted here (10 amp recommended). The other white-yellow wires are spare and should be covered with insulating tape to prevent shorting to the frame, etc. *Goto step 10*.

For **NEGATIVE GROUND** electrics:

8. Take one of the positive ignition feed wires previously removed from the ignition coils and connect to ignition coil#3 positive (+) terminal. If desired, an in-line fuse can be fitted here (10 amp recommended). The other white-yellow wires are spare and should be covered with insulating tape to prevent shorting to the frame, etc.
9. Take the black wire from the ignition module, cut to length and connect to a good grounding point. The grounding terminal on the condenser unit can be used, or fit a ring crimp connector to the wire and connect to a good grounding point on the frame, ideally the battery negative (–) terminal.
10. The GREY wire is provided an output signal to drive an electronic tachometer, if fitted. This is a 12 volt output and provides 1.5 pulses per engine revolution (or 3 pulses per 2 engine revolutions). If required, connect the grey wire to the tachometer signal input wire/terminal. If you have a mechanical tacho or an incompatible type (e.g. Scitsu or Krober), leave the wire unconnected and insulate the end of the wire.
11. Refit the main fuse/reconnect the battery.
12. Goto the IGNITION TIMING section.

WIRING DIAGRAM

**POSITIVE GROUND (STANDARD)**

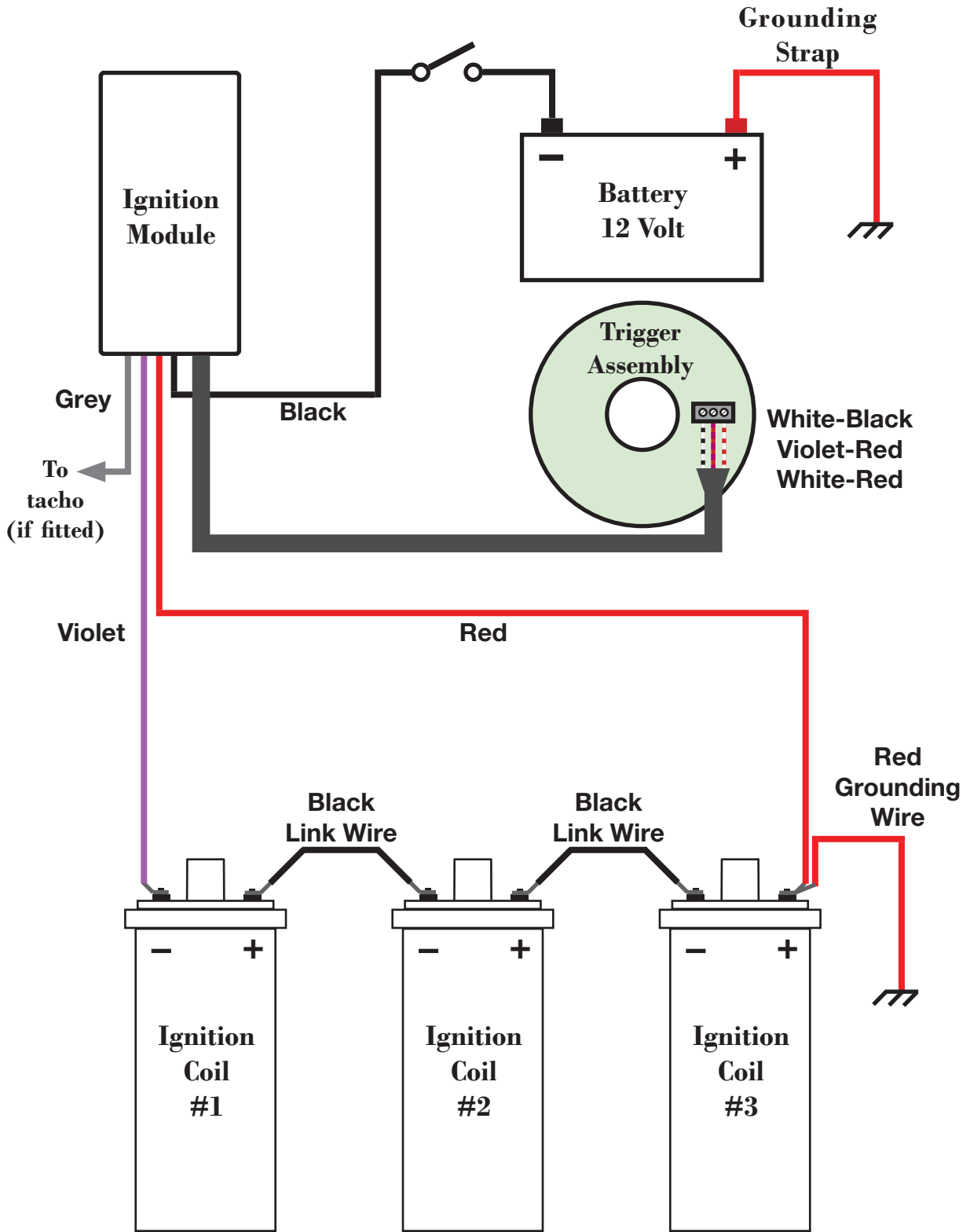

# WIRING DIAGRAM

# **NEGATIVE GROUND**

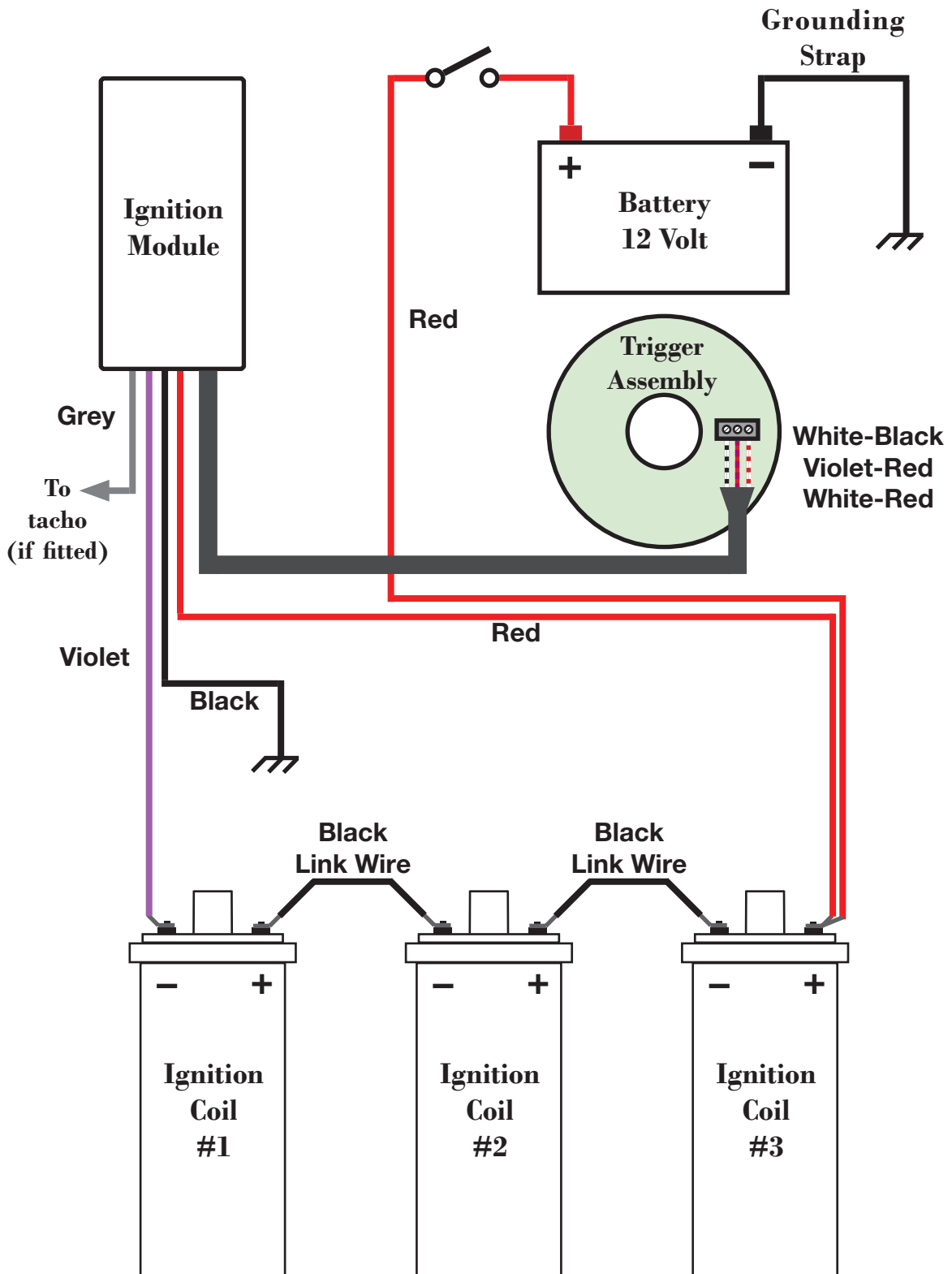

## Ignition Timing      See figs 4-6 on page 11

1. Switch off the ignition.
2. If necessary, slightly loosen the trigger pillar fixings so that the trigger can be rotated by hand.

**Warning: risk of electric shock.**

**Keep hands & body away from coils, ht leads, caps and plugs**

3. The following operations may produce sparks from the plugs. It is recommended that the violet wire be temporarily disconnected from the negative terminal of ignition coil #1; place insulating tape over the end of the connector to preventing shorting to ground or other connections. This will prevent any undesired sparks whilst timing. Alternatively, the spark plugs can be removed, inserted into the plug caps and grounded onto the cylinder head, *but note that the warning above applies.*
4. Reconnect the battery.
5. For clockwise rotor rotation (standard for Triumph/Bsa Triples):
  - If not already done, rotate the trigger to the fully counter-clockwise position, as per fig 4.
  - Switch the ignition on. The red timing light will normally be OFF.
  - Rotate the trigger clockwise until it is positioned as per fig 5, (the red timing light may turn ON then OFF).
  - Rotate the trigger *slowly* counter-clockwise until the red timing light turns ON, see fig 6.
  - If the red timing light does not turn ON, leave the ignition switch on and repeat the previous steps (figs. 4, 5 & 6) as required, until the trigger is calibrated (red light turns on in fig 6).
  - Carefully tighten the pillar fixings. Do not over-tighten or the trigger board may become distorted.
  - Switch the ignition off.
6. Reconnect the violet wire to ignition coil #1, if disconnected earlier. Refit the spark plugs/caps, if removed earlier.
7. Refit the battery cover, seat etc. as required.
8. The engine should now start, and after warming up should idle well, provided everything else is in good order and correctly adjusted. The ignition will advance as per the programmed advance map (see fig 1, on page 9).
9. The final timing can be checked and (if required) fine-tuned with a strobe timing light. This process will ensure that the timing has been set accurately, for best performance. The ignition timing is adjusted by moving the trigger assembly a small amount at a time on its adjustment slots. Proceed as follows:
  - Warm the engine for 4-5 minutes.
  - Connect a Xenon (white light) strobe lamp. It is recommend that a separate battery be used to power the strobe.
  - All plugs fire at the same time (wasted spark system), therefore it does not matter which spark plug wire is used to trigger the strobe.
  - Time the engine to the required full advance mark, with the engine running at 4000+ rpm.
  - The standard timing mark is at 38° btdc.
  - **For safety, switch the ignition off between adjustments.**
  - To advance the timing, rotate the trigger counter-clockwise.
  - To retard the timing, rotate the trigger clockwise.
  - Make very small adjustments; 1° of trigger movement is equivalent to 2° of crankshaft adjustment.
  - To assist with timing adjustment, the trigger board has calibration marks on the outer edge, equivalent to crankshaft degrees.



10. Refit the contact-breaker cover.
11. The timing is now set for life. The system requires no maintenance, but for satisfactory and reliable operation the wiring, battery, charging system, coils, plug wires, plugs and carburetors must be maintained in good order.

Fig. 1

### Altair Triumph/Bsa Triple Ignition Advance: MAP017

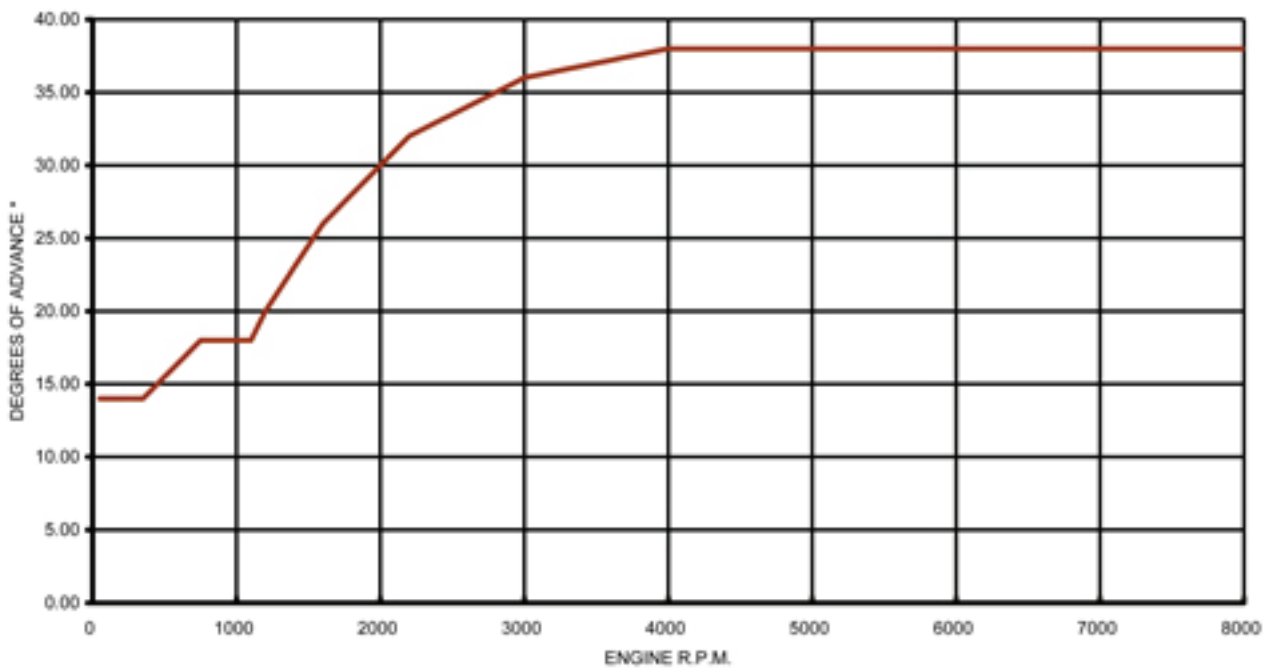

\* Relative to static ignition timing

## Trigger assembly

Fig. 2

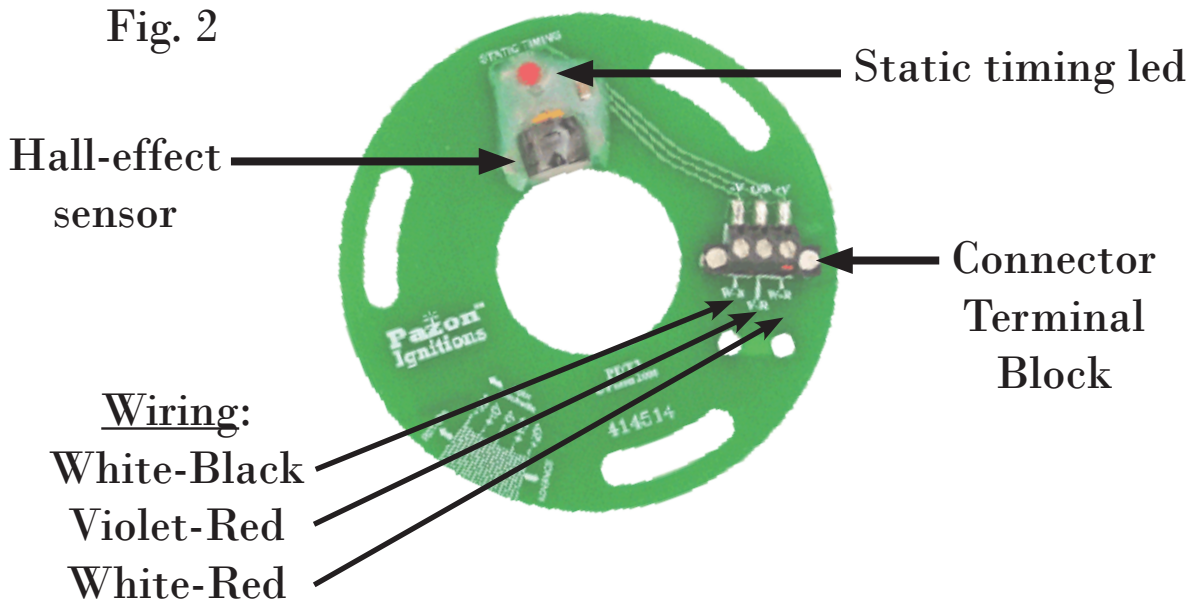

## Contact-breaker housing

Fig. 3

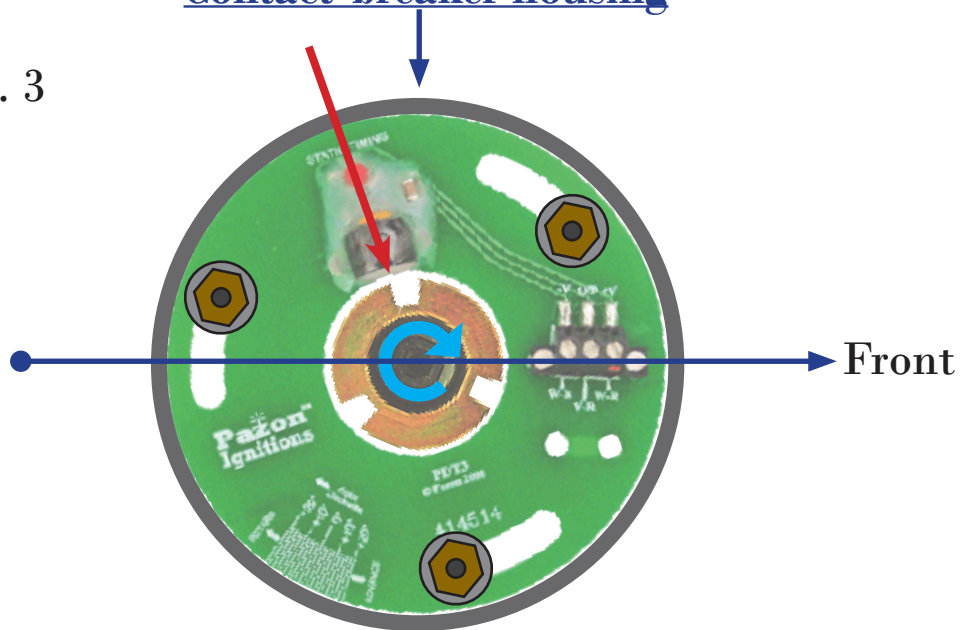

### Rotor and trigger start positions

Right-hand cylinder at  
full advance timing mark ( $38^\circ$  BTDC)  
on compression

- Rotate trigger to fully counter-clockwise position
- Align end of rotor slot with centre of sensor (as per red arrow)

**Static Ignition Timing**  
**CLOCKWISE Rotor Rotation**  
(Wiring not shown)

Fig. 4

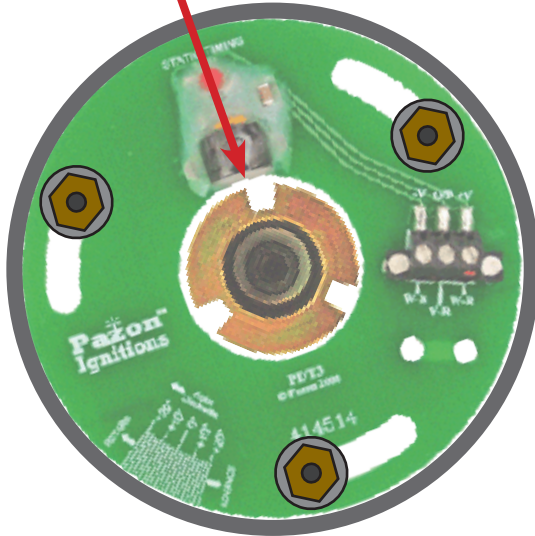

Start position

Switch ignition on

Fig. 5

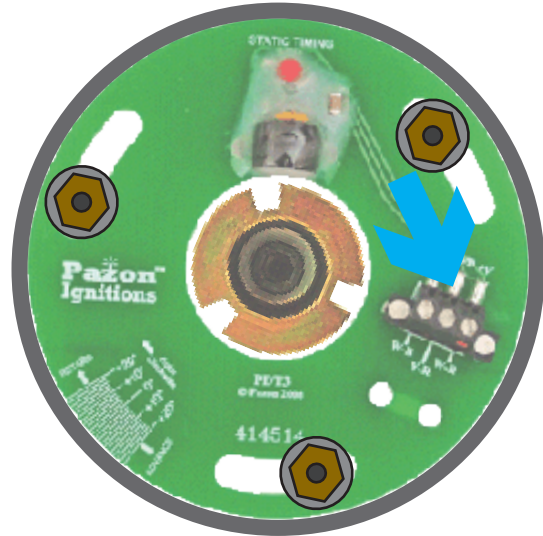

Turn trigger clockwise until start of rotor slot aligns with centre of sensor

Fig. 6



Turn trigger very slowly counter-clockwise until red timing light turns on\*, *stop turning*

\* See accompanying text on page 8 for a full description of the static timing light operation

## Terms, Conditions and Warranty

- Use of this product indicates your acceptance of this notice.
- The product design, firmware & literature is Copyright © 2011 PAZON IGNITIONS LTD. and is protected under international copyright, trademark & treaty provisions.
- To provide the best ignition systems possible, Pazon Ignitions Ltd. reserves the right to alter and improve the specifications of its products without prior notice.

## Ignition Systems

- Pazon Ignitions warrants to the original purchaser that the Pazon Ignition System be free from defects in workmanship & parts under normal use for a period of 7½ years from date of purchase.

## Ignition Spares

- Spares are defined as item(s) not purchased as part of a complete ignition system. Pazon Ignitions warrants to the original purchaser that these item(s) be free from defects in workmanship & parts under normal use for a period of one year from date of purchase.
- Ignition coils will only be covered by the warranty if it can be proved that the fault is due to a manufacturing fault within the coil.

## Limitation of Liability

- In no event shall Pazon Ignitions' liability related to the product exceed the purchase price actually paid for the product.
- Neither PAZON nor its suppliers shall in any event be liable for any damages whatsoever arising out of or related to the use or inability to use the product, including but not limited to the direct, indirect, special, incidental or consequential damages, or other pecuniary loss.
- This warranty will be void if the product or parts have been altered, damaged, abused or installed incorrectly.
- This warranty will be void if parts supplied by Pazon Ignitions are used with other makes of ignition. Your statutory rights are not affected.

## Warranty Claims

- To make a claim under warranty, the product must be returned to Pazon Ignitions or its authorized representative, with a copy of your receipt (or evidence of date and place of purchase), within the warranty period. Include a detailed description of the problem and why you believe there is a fault within the ignition system.
- The system must be returned postage paid.  
Proof of posting is not proof of receipt, therefore we recommend using a recorded mail service.
- Upon receipt we will thoroughly test the returned items and repair or replace any items found to be faulty and covered by the warranty.
- Please allow seven working days from receipt of the returned parts before contacting us, to allow sufficient time for a thorough test and evaluation.
- PLEASE CONTACT PAZON IGNITIONS FOR RETURN INSTRUCTIONS.

✉ Pazon Ignitions Ltd, 274 Hot Springs Road, RD 2,  
Katikati 3178, Bay of Plenty, New Zealand  
☎ TELEPHONE: +64 (0) 7549 5878    📠 FAX: +64 (0) 7549 5879  
EMAIL: [ignition@pazon.com](mailto:ignition@pazon.com)    WEB: [www.pazon.com](http://www.pazon.com)

AL3 V1.0