

Pazon

IGNITIONS WITH THE 7½ YEAR WARRANTY

Sure-Fire™

TRIUMPH BSA

ELECTRONIC IGNITION
FOR UNIT CONSTRUCTION
SINGLE CYLINDER MOTORCYCLES
WITH POINTS IN THE SIDE CASING
& 6 VOLT ELECTRICS
POSITIVE OR NEGATIVE GROUND



SYSTEM TYPE: PA1-6

Sure-Fire System Contents:

- IGNITION MODULE (6V)
- TRIGGER ASSEMBLY
- MAGNETIC ROTOR
- ¼" BSF BOLT
- ¼" UNF BOLT
- ¼" FLAT WASHER
- RED GROUNDING WIRE
- CRIMP CONNECTORS & INSULATORS
- LARGE & SMALL CABLE TIES
- CABLE TIE ADHESIVE MOUNTING BASE

WARNING: RISK OF ELECTRIC SHOCK **ALWAYS TURN OFF BEFORE WORKING ON THE SYSTEM**

BEFORE FITTING, PLEASE READ THESE INSTRUCTIONS CAREFULLY, INCLUDING THE NOTICE ON PAGE 12.

WARNING: FOR MOTORCYCLES WITH ALTERNATOR & RECTIFIER TYPE CHARGING SYSTEMS. UNLIKE THE LATER 12 VOLT SYSTEMS, THIS TYPE OF 6 VOLT CHARGING SYSTEM HAS NO SUPPLY VOLTAGE CONTROL (I.E. ZENER DIODE), RELYING INSTEAD ON LOADING FROM THE BATTERY (& LIGHTING) TO KEEP THE VOLTAGE WITHIN ACCEPTABLE LIMITS. IF THE BATTERY SHOULD BECOME DISCONNECTED WHILST RUNNING, IT IS LIKELY THAT EXCESSIVE VOLTAGE WILL BE FED INTO THE WIRING HARNESS. THIS MAY LEAD TO FAILURE OF THE IGNITION MODULE. FAILURE OF A MODULE DUE TO EXCESSIVE SUPPLY VOLTAGE WILL NOT BE COVERED BY THE WARRANTY. WE RECOMMEND THAT THE BATTERY CELLS ARE REGULARLY CHECKED AND THAT THE BATTERY CONNECTIONS ARE KEPT SECURE & TIGHT AT ALL TIMES. BULB FAILURE AND/OR BATTERY BOILING MAY INDICATE A PROBLEM WITH THE CHARGING. 6 VOLT DYNAMO CHARGING SYSTEMS ARE NOT AFFECTED BY THIS PROBLEM, PROVIDED THAT THE REGULATOR IS FUNCTIONING CORRECTLY.

Sure-Fire Installation Instructions:

1. Remove the petrol tank (and seat if necessary) to gain access to the ignition coil, condenser and wiring.
2. For safety, disconnect the battery, if fitted (preferably both terminals).
3. Remove the spark plug.
4. Remove the alternator rotor cover (if fitted).
5. Loosen the auto-advance centre bolt. Rotate the engine to the correct full advance timing position for your machine (see table on page 8), using one of these methods:
 - Models from 1967 on: use the marks provided for strobe timing on the rotor & chaincase (inside the rotor cover). Unless these marks are known to be accurate it is recommended that they are checked for correct alignment. These marks should line up at the full advance

position, check using one of the methods below and, if necessary, re-mark the rotor.

- Models from 1969 on: use the timing plug on the left-hand crankcase
 - Use a degree disc on the crankshaft / camshaft (see table on page 8)
 - Use a dial gauge down the spark plug hole (see table on page 8)
5. Remove kickstart, gear lever and outer timing cover.
 6. Remove the contact-breaker plate and lead from the outer timing cover.
 7. Remove the centre bolt securing the auto-advance unit. Remove the complete auto-advance unit with an extractor bolt or by tapping it gently sideways.
 8. Fit the magnetic rotor in place of the auto-advance unit, with the magnets/red marks positioned at approx. 3 & 9 o'clock. The magnetic rotor has a male taper which fits into the taper in the end of the camshaft. There is no keyway, allowing it to be fitted in any desired position.
 9. Using the ¼" washer and the appropriate bolt (UNF or BSF), pass the bolt through the centre of the magnetic rotor and into the thread in the camshaft. Finger tighten only at this stage. The magnetic rotor centre thread (metric M8) is provided for attaching a puller, if the rotor should need to be removed for engine servicing, etc.
 10. Taking the ignition trigger assembly, insert a small cable tie into the two holes in front of the connector block on the ignition trigger. This will be used later to secure the two wires to the plate.
 11. Fit the ignition trigger plate with the adjustable slots at approx. 6 & 12 o'clock, using the original pillar fixings & washers, positioned in the centre of the slots (to allow for adjustment in either direction). Handle the trigger with care.
 12. Check that the engine is still at the correct full advance position, then adjust the magnetic rotor position so that one of the red marks is centrally behind the static timing hole at 9 o'clock (see fig. 4, page 9). [If your machine's camshaft rotates clockwise, refer to fig. 3]. Gently tap the rotor into the taper & tighten the centre bolt, using a 3/16" allen key.
 13. Replace the outer timing cover, gear lever & kickstart.

WIRING:

14. All connections must be of the highest quality, use crimped or soldered connections; twisted wires will not give a satisfactory operation. Avoid coiling up surplus lead.
15. Find a suitable place for the ignition module, preferably near to the ignition coil. Secure the ignition module to the frame using one or more large cable ties. An adhesive mounting base is provided; this can be affixed to the underside of the module and the cable tie passed through and around the module and frame. Do not completely wrap the module in foam rubber.
16. Disconnect the external condensor (if fitted) and the existing contact-

- breaker wire from the positive (+) ignition coil terminal (standard positive ground) or from the negative (-) ignition coil terminal (if wired for negative ground).
17. If currently wired for negative ground electrics goto step 18, otherwise disconnect all leads from the negative (-) ignition coil terminal; this includes the ignition switch supply (normally a white wire).
 18. Take the VIOLET wire from the ignition module, cut to length and fit an insulator and female spade connector to the end. Connect to the negative (-) terminal on the ignition coil. See figs.1/2 on page 7.
 19. Take the RED wire from the ignition module, cut to length and fit an insulator and female spade connector to the end. Connect to the positive (+) terminal on the ignition coil. See figs.1/2 on page 7.
 20. For NEGATIVE GROUND electrics, go to step 23.
 21. For POSITIVE GROUND electrics (standard):
Take the WHITE wire from the module, cut to length and fit an insulator and male spade connector to the end. Connect to the ignition feed wires previously removed from the ignition coil in step 17.
 22. Take the RED GROUNDING WIRE, fit the female spade connector end to the positive (+) terminal on the ignition coil. Cut to length and fit a ring terminal on the other end and connect to a good grounding point on the frame, ideally the battery positive (+) terminal. See fig.1 GOTO STEP 25.
 23. For NEGATIVE GROUND electrics:
If the electrics are currently wired for negative ground, the positive feed from the ignition switch should already be present on the positive terminal on the ignition coil. See fig.2
 24. Take the WHITE wire from the module, cut to length and fit a ring terminal connector to the end. Connect to a good grounding point on the frame, ideally the battery negative (—) terminal. See fig.2
 25. Allowing a minimum of 50mm/2” of excess wire between the trigger and ignition module, route the white-black & yellow-black wires from the ignition module down to the connector block on the ignition trigger and cut to length. Using tie-straps or tape, secure these wires to the frame, preferably away from other wiring (such as the alternator wires). Slide a small length of sleeving over the two wires. With a pair of wire strippers/cutters, carefully remove 4-5mm of insulation from the ends of the two wires. Insert the yellow-black wire into the left-hand screw terminal and the white-black wire into the right-hand screw terminal. The connector block terminals are marked on the trigger plate “Y/B” and “W/B”. Tighten the two screws. Secure the wires and sleeving with the cable tie, fitted in step 10. If preferred, the two wires can be soldered directly to the trigger using the two solder pads provided in front of the connector block. It is essential that these two wires are connected the right way around for correct operation of the ignition system. Reversed connections will give very retarded ignition timing.

26. Remove any redundant wires or insulate bare ends. Re-check all connections are good and tight; any loose crimps should be removed, slightly closed up and refitted, or preferably replaced.
27. Refit spark plug, tank, fuel lines, battery & seat, as required. Top up the gearbox, if oil has been lost.
28. **FINAL IGNITION TIMING**

LATER MODELS (1967 on):

Start engine and run for 4-5 minutes to warm up. Using a white light strobe, time the engine to the full advance mark (previously used in step 5) with the engine running up to 4000rpm. If running in, you may strobe time at 3000rpm to the full advance figure less approx. 2°. Stop the engine and adjust the timing by making very small movements of the ignition trigger on its slotted holes; moving the trigger by 1° is equivalent to 2° of the crankshaft. When using a strobe light, you may see a small amount of advance above 4000rpm, this is normal. To advance the timing, turn the trigger against the direction of the magnetic rotor (normally clockwise). To retard the timing, turn the trigger in the same direction as the magnetic rotor (normally anti-clockwise). In the unlikely event that the timing cannot be obtained before the end of the adjustment slots, the magnetic rotor will need to be slackened off and repositioned slightly. Road test the machine and make any final timing adjustments (if necessary) for optimum performance.

EARLY MODELS:

These have no provision for strobe timing.

WARNING: RISK OF SERIOUS INJURY, DO NOT ATTEMPT TO STROBE TIME BY RUNNING THE ENGINE WITH THE CHAINCASE REMOVED

For C15 and B40 machines, road test the machine and make any final timing adjustments (if necessary) for optimum performance. Adjust the timing by moving the trigger plate, as described for later models (above). The working advance range for this ignition system is approximately 20° crankshaft (10° camshaft).

29. Refit timing/contact-breaker cover. The timing is now set and requires no further adjustment. However, please note that for satisfactory operation of this ignition system it is important that the wiring, ignition coil, switch, battery, h.t. lead, plug and plug cap are in good order.

POSITIVE GROUND (standard)

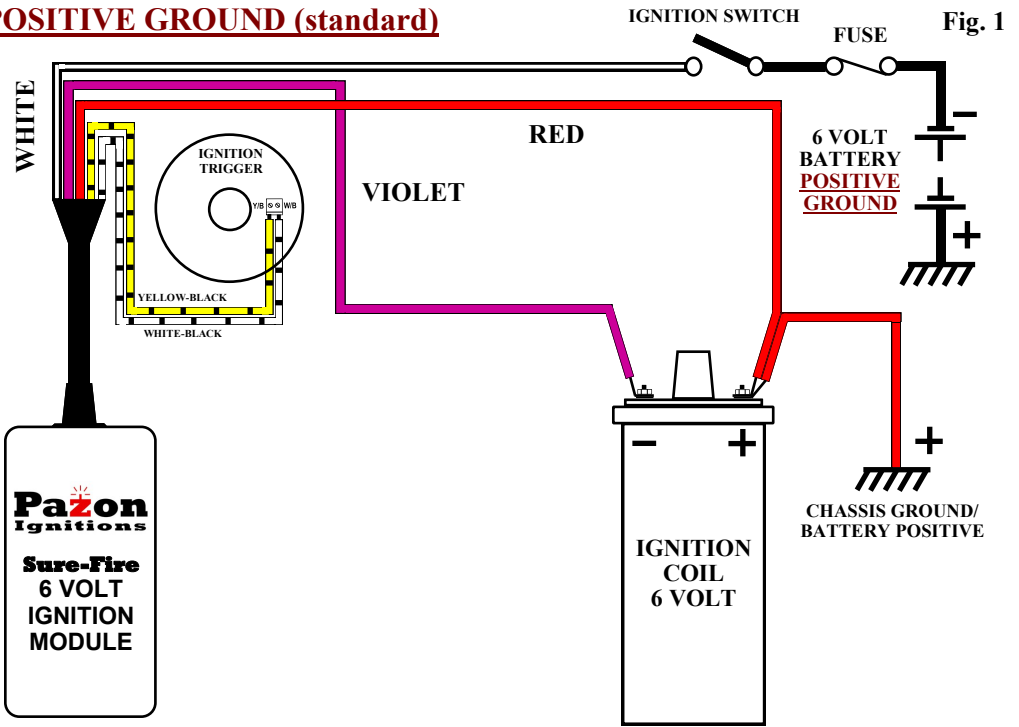

NEGATIVE GROUND

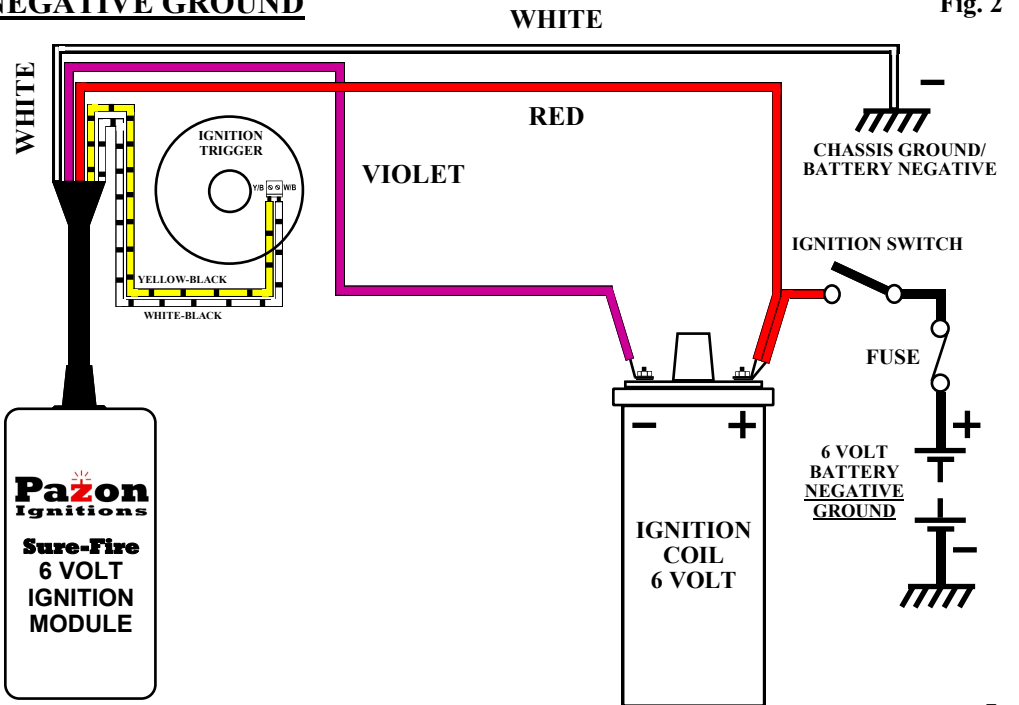

Table 1

MOTORCYCLE (ALL VERSIONS)	TIMING HOLE	FULL ADVANCE TIMING
BSA C15/B40	ANTI-CLOCKWISE	33.5° (9/32", 7mm)
BSA B25	ANTI-CLOCKWISE	37° (0.342", 8.69mm)
BSA B44	ANTI-CLOCKWISE	28° (0.266", 6.75mm)
BSA B50	ANTI-CLOCKWISE	34° ('72-'73) (0.385", 9.78mm) 30° ('71)
TRIUMPH T20/M (CUB)	ANTI-CLOCKWISE	36° (early models) 32° ('67)

ABOVE FIGURES ARE FOR ENGINES IN A STANDARD STATE OF TUNE

NOTE: IF USING A DEGREE DISC ATTACHED TO THE CAMSHAFT, THE FULL ADVANCE FIGURE READING ON THE DISC MUST BE HALVED. E.G. FOR 34°, SET ENGINE TO T.D.C., ZERO DEGREE DISC AND ROTATE ENGINE BACKWARDS UNTIL DEGREE DISC HAS TRAVELLED 17°



Sure-Fire Ignition Timing
TRIUMPH/BSA SINGLES

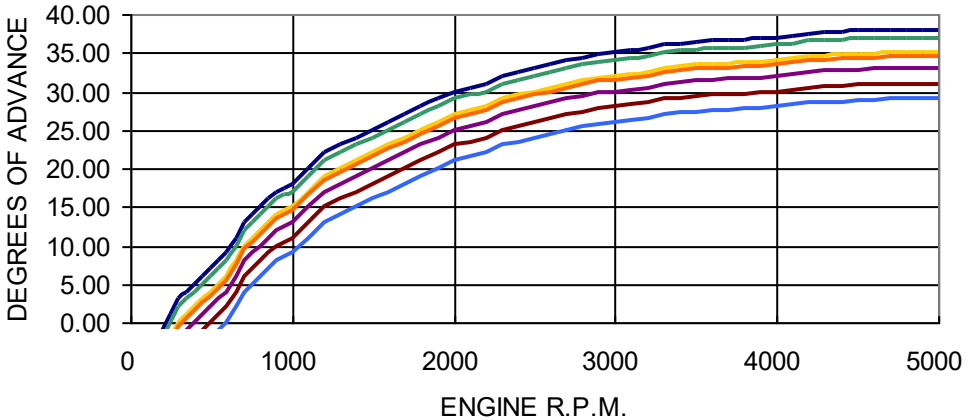

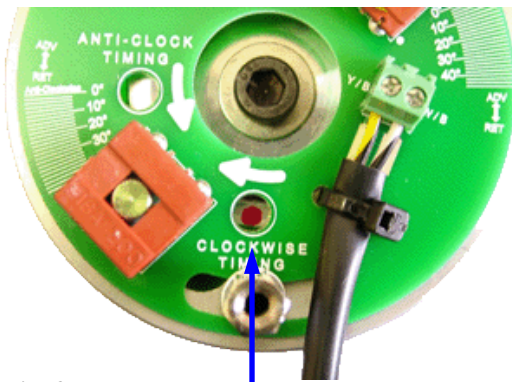

Fig. 3

CLOCKWISE ROTATION
RED INDICATOR MARK
ON MAGNETIC ROTOR ALIGNED
UNDER CLOCKWISE TIMING HOLE,
ENGINE SET AT FULL ADVANCE

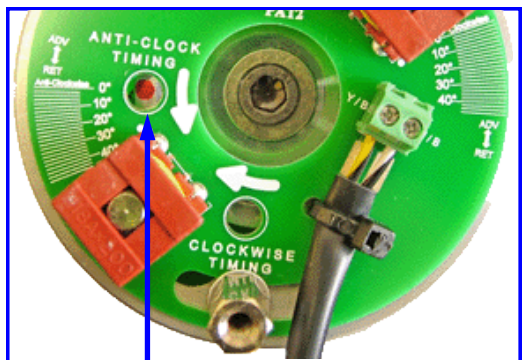

Fig. 4

ANTI-CLOCKWISE ROTATION
RED INDICATOR MARK
ON MAGNETIC ROTOR ALIGNED
UNDER ANTI-CLOCKWISE
TIMING HOLE,
ENGINE SET AT FULL ADVANCE

Sure-Fire TECHNICAL DATA

Ignition Module (Part# PAM2-6)

Minimum Supply Voltage:

Maximum Supply Voltage:

Maximum Ignition Coil Peak Primary Voltage:

Maximum Ignition Coil Secondary Voltage:

Current Draw (Static):

Current Draw (Dynamic):

Maximum Ignition Coil Current Draw:

Ignition Coil Turn Off (Engine Static):

Minimum Cranking Speed:

Maximum Switching Rate:

6 Volts DC

8 Volts DC

400 Volts (Regulated)

Ignition Coil Dependent

0.05 Amps Max. (Ignition Coils Off)

Typically 1.5-2 Amps
(Coil Dependent)

5 Amps

3 Seconds (Typical)

100rpm (Typical)

10,000 Sparks/Minute (Typical)

Ignition Trigger (Part# PAT2)

Trigger Type:

Configuration:

Trigger coil resistance:

Total trigger resistance:

2-Way Connector Block Wire Size:

Twin ferrite core

Series connected

55Ω @ 20°C.

110Ω @ 20°C.

0.75mm² max.

Ignition Magnetic Rotor (Part# PAR2)

Material:

Magnet Polarity:

Aluminium + inner steel ring

South poles both face outwards

Ignition Coils

For best results with this system, use an ignition coil with a primary resistance of 1.5 to 2.5ohms (standard Lucas/PVL 6 volt coil, or equivalent, e.g. Pazon part# IC06). CDI type and some electronic ignition coils are incompatible with this system; for suitability check the primary resistance is 1.5 ohms or more (measure across the + and — terminals with a multimeter).

For a twin-plug head, a 6 volt dual output coil with a primary resistance of between 1.5 to 2.5ohms (e.g. Pazon part# IC32) is satisfactory, but for best results on high compression/competition engines use two 3 volt coils (Pazon part# IC13), or two coils with a total primary resistance of between 1 to 2 ohms, connected in series (as for a twin cylinder).

Ignition coils can develop a short circuit to ground through the case, especially if the clamp is too tight. This can cause overheating of the affected coil and can also produce misfiring/bad running. Slacken the clamp and examine the coil casing for heavy crease marks. If in doubt replace the coil.

HT Lead, Spark Plug & Plug Cap

Always use copper cored ht lead. Do not use carbon-fibre (resistive) lead.

Provided you have the correct grade of plug for your engine and that it is in good order, there is no need to change it when fitting this system. The spark plug gap can be left as standard, as a guide 0.025"-0.028" should be sufficient.

We recommend fitting an NGK 5K resistor (suppressor) type plug cap (or similar good quality make), but you can also fit a non-resistor cap.

General Data/Troubleshooting

This system can be adapted to work on many types of engine, provided that the required firing interval is every 360° crankshaft / 180° camshaft. This ignition is of the wasted spark type, i.e. sparking occurs every turn of the engine (on compression & exhaust strokes).

Wiring should be cut to the correct length. Excess wire should not be coiled up; this can affect the correct running of the ignition system. Where possible the wires from the ignition trigger should be run separately from the rest of the wiring loom, especially the alternator stator wiring.

The frame/chassis must act as an electrical return (ground/earth), whether positive or negative ground. If the engine is rubber mounted a good ground/earth strap must be provided.

This system can be run total-loss from a battery only (e.g. for off-road applications).

The **Sure-Fire** ignition module features a simple self-test facility for producing sparks without turning the engine:

- Disconnect the ignition trigger wires (w-b & y-b) from the trigger.
- Switch ignition on.
- Take the trigger wires, touch together and open, approximately 1-2 times per second. A spark should be produced at the plug each time.
- If there are no sparks, check battery, switch, grounding, wiring, connections & ignition module.
- Continuous sparks without turning the engine indicates a poor supply to the ignition; check battery (bad cell), switch, grounding, & connections.

<http://www.pazon.com/news/9/SUREFIRE-FAULT-FINDING.html>

Terms & Conditions and Warranty

- Use of this product indicates your acceptance of this notice.
- The product design & literature is Copyright © PAZON IGNITIONS LTD. 2005-2020, and is protected under international copyright, trademark & treaty provisions.
- To provide the best ignition systems possible, PAZON IGNITIONS reserves the right to alter and improve the specifications of its products without prior notice.

Ignition Systems

- Pazon warrants to the original purchaser that the Pazon Ignition System be free from defects in workmanship & parts under normal use for a period of 7½ years from date of purchase.

Ignition Spares

- Spares are defined as item(s) not purchased as part of a complete ignition system. Pazon Ignitions warrants to the original purchaser that these item(s) be free from defects in workmanship & parts under normal use for a period of one year from date of purchase.
- Ignition coils will only be covered by the warranty if it can be proved that the fault is due to a manufacturing fault within the coil.

Limitation of Liability

- In no event shall Pazon Ignitions liability related to the product exceed the purchase price actually paid for the product.
- Neither Pazon Ignitions nor its suppliers shall in any event be liable for any damages whatsoever arising out of or related to the use or inability to use the product, including but not limited to the direct, indirect, special, incidental or consequential damages, or other pecuniary loss.
- This warranty will be void if the product or parts have been altered, damaged, abused or installed incorrectly.
- This warranty will be void if parts supplied by Pazon Ignitions are used with other makes of ignition. Your statutory rights are not affected.

Warranty Claims

- To make a claim under warranty, the product must be returned to PAZON IGNITIONS or its authorized representative, with a copy of your receipt (or evidence of date & place of purchase), within the warranty period.
- Include a detailed description of the problem and why you believe there is a fault within the ignition system.
- The system must be returned postage paid. Proof of posting is not proof of receipt, therefore we recommend using a recorded mail service.
- Upon receipt we will thoroughly test the returned items and repair or replace any items found to be faulty and covered by the warranty.
- Please allow seven working days from receipt of the returned parts before contacting us, to allow sufficient time for a thorough test and evaluation.
- PLEASE CONTACT PAZON IGNITIONS FOR RETURN INSTRUCTIONS.

✉ **Pazon Ignitions Ltd, 274 Hot Springs Road, RD 2,
Katikati 3178, Bay of Plenty, New Zealand**

☎ **TELEPHONE: +64 (0) 7549 5878** ☎ **FAX: +64 (0) 7549 5879**
EMAIL: ignition@pazon.com WEB: www.pazon.com