

Pazon
IGNITIONS WITH THE 7½ YEAR WARRANTY

Smart-Fire™



V-TWIN

**HIGH-PERFORMANCE
IGNITION SYSTEM**

12 VOLT



SYSTEM TYPE: PDV1

Smart-Fire APPLICATIONS

- VINCENT 50 DEGREE V-TWINS & SIMILAR APPLICATIONS WITH 12-VOLT ELECTRICS, POSITIVE OR NEGATIVE GROUND

FEATURES

- HIGH-POWER DIGITAL IGNITION MODULE (FULLY ENCAPSULATED)
- COMPATIBLE WITH 12 VOLT POSITIVE & NEGATIVE GROUND ELECTRICS
- FULLY PROGRAMMED IGNITION TIMING & COIL ENERGY CONTROL: IGNITION ADVANCE CURVE IS MAPPED FOR THE VINCENT V-TWIN ENGINE
- USER-PROGRAMMABLE REV.LIMITER BUTTON
- ELECTRONIC TACHOMETER OUTPUT
- PRECISION ENGINEERED STEEL TIMING DISC
- RELIABLE & RUGGED HALL-EFFECT SENSOR , INCLUDES ON-BOARD STATIC TIMING LIGHT, FOR EASY SETTING OF IGNITION TIMING
- LESS MAINTENANCE
- IMPROVED ENGINE PERFORMANCE, INCLUDING BETTER STARTING & SMOOTHER RUNNING
- FOR RACING APPLICATIONS: SPECIAL ADVANCE CURVES & REV-LIMITERS AVAILABLE
- COVERED BY MANUFACTURER'S 7½ YEAR WARRANTY
- MODULE SIZE(mm):
90 LONG x 65 WIDE (95 INC. MOUNTING BRACKETS)
x 30 DEEP, WEIGHT: 400g (INC. WIRES)

IGNITION SYSTEM COMPRISES:

- IGNITION MODULE (ALUMINIUM HOUSING WITH MOUNTING BRACKETS) & WIRING
- MAGNETO REPLACEMENT CAST HOUSING WITH PRE-INSTALLED TRIGGER ASSEMBLY & TIMING ROTOR
- DIGITAL IGNITION COIL (DUAL OUTPUT)
- H.T. LEADS (COPPER-CORED)
- PLUG CAPS (5K RESISTOR TYPE)
- FIXING SCREWS, WASHERS & NUTS
- CRIMP TERMINAL CONNECTORS & INSULATORS
- RED GROUNDING WIRE
- TIE-STRAPS

Smart-Fire FITTING INSTRUCTIONS

**WARNING: THIS SYSTEM PRODUCES VERY HIGH VOLTAGES,
ALWAYS SWITCH OFF BEFORE WORKING ON THE SYSTEM.**

Before fitting, please read these instructions carefully, including the notice on page 16.

This system is designed to work only with the special digital ignition coil provided with the system. 5K resistor plug caps as supplied with the system should be fitted to the h.t. leads. Alternatively, resistor spark plugs can be used. Attempting to run the system without resistor type caps or plugs will result in excessive radio frequency interference (r.f.i.), which may cause bad running, misfiring and loss of ignition. For reliability, copper or steel cored h.t. lead should be used, we do not recommend using carbon fibre leads. This ignition is a wasted spark system, therefore both plugs fire at the same time.

These instructions are a general guide for installing the system to various machines and therefore it may be necessary to modify the length or routing of some wires in order to complete the installation. All connections should be made using good quality crimped or soldered connections; twisted wires will not give satisfactory operation. Wiring should be trimmed to the correct length, excess wire should not be coiled up as this can affect the correct running of the ignition system. If electric welding is to be carried out, the ignition module should be disconnected and its connectors covered with insulation, to help prevent stray sparks from damaging the module. If in doubt, remove the unit from the machine.

1. Disconnect the battery.
2. Remove the timing cover and automatic timing device (if fitted).
3. Remove the magneto cowl and magneto. Fit the magneto replacement unit in place of the magneto (using the original fixings). **In some cases the long nut may need to be waisted (reduced in diameter) in order to clear the body.**
4. Fit the ignition module in a convenient place, preferably under the battery platform, or behind the magneto cowl. The unit can be orientated in any position, but this should be onto a flat surface, if possible. Secure the unit by the mounting flanges using the two M5 bolts, shakeproof washers & nuts. Alternatively, the mounting

flanges can be removed by slackening the bracket securing screws and sliding the brackets out of the dovetail slots.

5. Fit the ignition coil in a convenient place, away from the ignition module & magneto replacement unit. Suspend the coil by the two mounting lugs, using the M5 bolts, washers & nuts. Alternatively, to avoid the need for drilling or a mounting bracket, the coil can be rubber mounted using two small pieces of rubber tubing (such as fuel pipe or heater hose) & two large tie-straps, see figs. 1 / 1a. The coil can then be secured by passing the tie-straps around the frame tube & fully tightening the tie-straps. Fit the new h.t. leads by pushing the brass connectors fully into the h.t. outlets of the coil, along with the rubber boots. Small tie-straps can be placed around the rubber boots & tightened to give extra security, if desired. The h.t. leads should now be cut to length, if necessary, & the plug caps screwed onto the ends of the h.t. leads. Since both h.t. leads fire together, it does not matter which h.t. lead goes to which plug. Push the plug caps firmly onto the plugs, they should click into place.



FIG. 1



FIG. 1a

WIRING

(PLEASE SEE WIRING SCHEMATICS ON PAGES 8 & 9)

1. The ignition trigger wires (sleeved) are coloured: White—Black, Violet—Red & White—Red. Allowing some slack in the cable, route these wires down to the magneto replacement housing, remove the housing cap & feed through the grommet in the cap. Route the wires around to the ignition trigger 3-way connector block. Allowing some movement in the cable (for setting the ignition timing), cut the cable & sleeving to length. Carefully strip back 4-5mm of insulation from the ends of the three wires. Insert the wires into the connector block (from left to right) as follows:
White—Black, Violet—Red & White—Red. Tighten the screws with a small screwdriver. Secure the sleeved wires to the trigger plate with a small cable tie-strap, using the set of holes provided.
See fig. 3, page 12. Make sure that excess wire is not coiled up inside the housing, which could be damaged by the spinning rotor in the centre.
2. Connect the violet wire from the ignition module to the negative (—) terminal of the ignition coil (left-hand spade connector), using a female crimp connector and insulating cover.
3. Connect the red wire from the ignition module to the positive (+) terminal of the ignition coil (right-hand spade connector), using a female piggyback crimp connector and insulating cover.

**Re-check the connections to the ignition coil;
reverse polarity may damage the coil.**

For **positive ground** electrics, please go to step 5.

4. For **negative ground** electrics: connect the black wire from the ignition module to a good grounding point on the frame or directly to the battery negative (—), using a ring terminal. Connect the spare terminal on the piggyback connector (on the positive side of the second ignition coil), to a switched positive supply (+12 volts), preferably via a fuse (8-10 amp recommended) and through the ammeter (if fitted). Go to step 7.

5. For positive ground electrics: connect the spare terminal on the piggyback connector (on the positive side of the ignition coil) to a good grounding point on the frame or directly to the battery positive (+), using the red grounding wire provided. Connect this wire to the coil end using a female spade connector and insulating cover. Connect the other end to ground using a ring terminal.
6. Connect the black wire from the ignition module, to a switched negative supply, preferably via a fuse (8-10 amp. Recommended) and through the ammeter (if fitted).
7. Suggestions for the choice of switch can be a spare position on the headlamp switch (if available), a second dip switch on the handlebars or a key switch located in the headlamp shell. It is important that the switch is in good condition; corroded or dirty contacts will cause misfiring/cutting out.
8. The **ORANGE** wire is an *ignition inhibit* input. This can be connected to a grounding kill switch or a hidden security switch, provided that the vehicle is negative ground. If not required, place insulating tape over the end of the wire to prevent shorting out.
9. The **GREY** wire is a tacho output signal for driving an electronic tachometer, if fitted. This is a 12 volt pulsed output and provides 1 pulse per two engine revolutions (0.5 pulses/rev). If your tacho requires a different pulse rate, contact Pazon Ignitions. Connect to the tacho signal input terminal/wire. If you have a mechanical tacho, an inductive pickup tacho (e.g. Scitsu) or no tacho, then leave unconnected; cut short the wire & and insulate the wire end.
10. Any remaining wires which may be present on the ignition module are for factory use and should remain unconnected and insulated, as supplied.

**WARNING: TURN OFF/DISCONNECT THE BATTERY
BEFORE WORKING ON THE SYSTEM
HIGH VOLTAGES CAN KILL**

POSITIVE GROUND

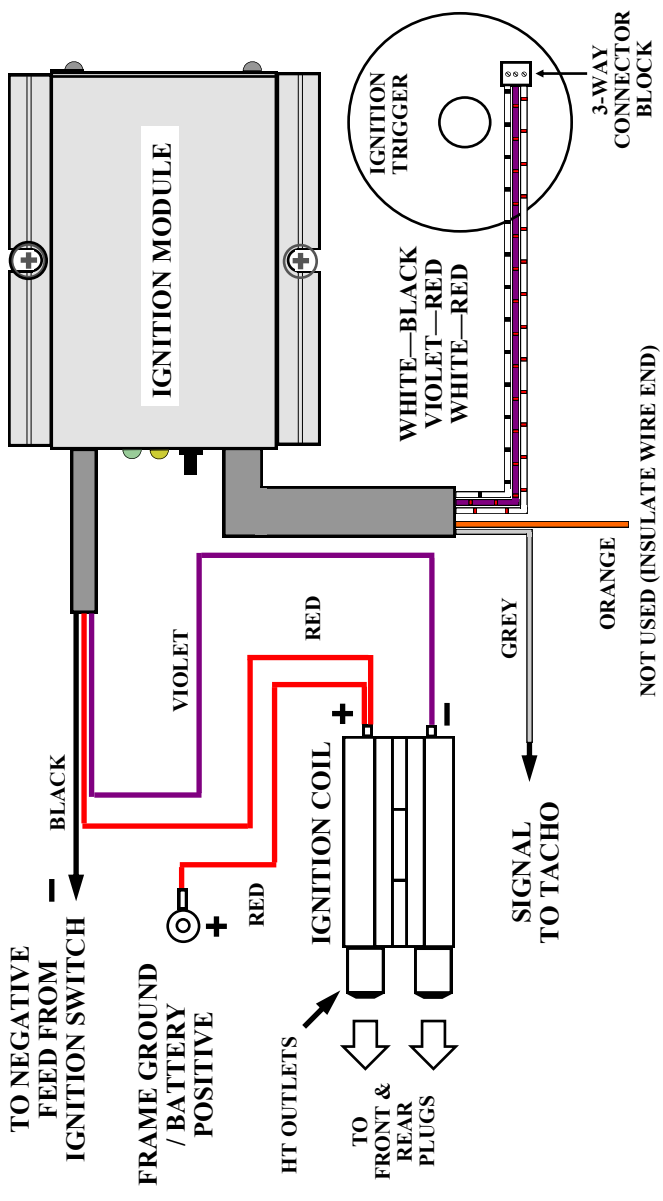

WARNING: TURN OFF/DISCONNECT THE BATTERY BEFORE WORKING ON THE SYSTEM HIGH VOLTAGES CAN KILL

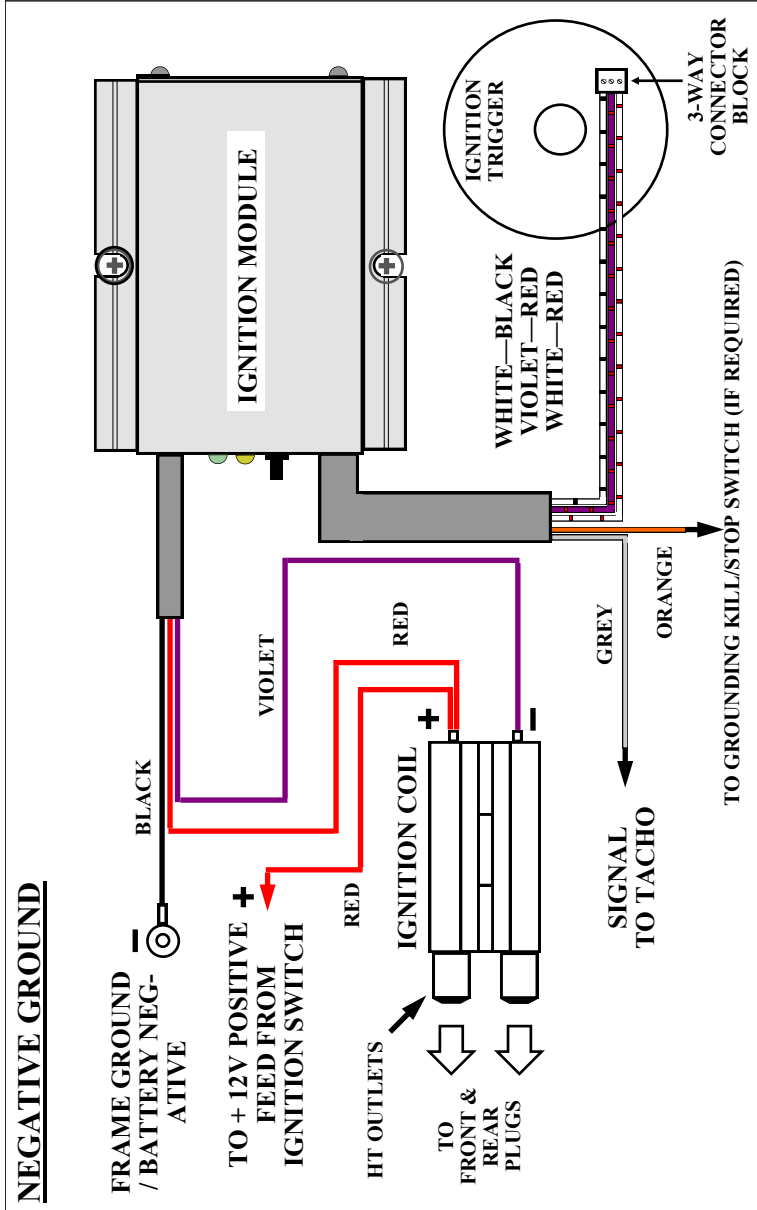

TIMING (PLEASE SEE PAGE 12/13, FIGS. 2 - 6)

1. Switch off ignition or disconnect the battery.
2. The automatic advance unit is no longer required and should be removed. However, if it is to remain in place it must be locked solid by whatever method is available. The ignition module includes electronic advance/retard suited to the Vincent engine. The preferred alternative is to replace the automatic advance unit with a solid drive pinion, please contact your dealer for the necessary parts, if required.
3. Remove spark plugs. **Set the rear piston at TDC (top dead centre) on the compression stroke.**
4. Remove the cover from the magneto replacement unit.
5. Slightly loosen the hex pillar fixings. Rotate the trigger assembly fully counter-clockwise on its adjustment slots. See fig. 4, page 13.
6. Loosen the steel timing rotor cap screw using an M5 hex key.
7. Without rotating the engine, position the rotor with the two tabs as shown in fig. 5, page 13. One of the tabs should be aligned approximately with the centre of the static timing led on the trigger board (indicated by the red line on fig. 5). The other tab will be pointing approximately at the 'n' in the Pazon logo. Tighten the rotor cap screw & re-check the position.
8. The following operations may produce a spark from the plugs, therefore it is recommended that the spark plugs be removed and grounded onto the cylinder head (with the plug caps & h.t. leads connected to them). Alternatively, the violet wire can be temporarily disconnected from the negative terminal of the ignition coil, place insulating tape over the end of the connector to prevent shorting to ground. This will prevent any undesired sparks whilst timing.
9. (Reconnect battery).
 - Recheck that the trigger assembly is in the fully counter-clockwise position (fig. 4, page 13).
 - Switch the ignition on, the small green (power) led on the ignition module should turn ON. The red static timing led on the trigger assembly should be OFF (you may see it blink very briefly).
 - Rotate the trigger assembly **very slowly clockwise** until the red timing led turns ON, stop rotating. This is the static timing point for TDC on the rear cylinder. See fig. 6, page 13.
 - Keeping the trigger in position, finger tighten the pillar fixings.
 - If you make a mistake, switch the ignition off and restart from the beginning of step 9.

10. Tighten the hex pillar fixings using a 7mm hex driver or spanner. Do not over-tighten or the trigger plate may become distorted.
11. Switch off the ignition.
12. Replace the cover on the magneto replacement unit, making sure that excess wire is not coiled up inside the housing, which could be damaged by the spinning rotor in the centre.
13. Refit the spark plugs & caps, if removed earlier. Reconnect the violet wire to the ignition coil, if disconnected in step 8.
14. The engine should now start and after warming up should tick over well, provided everything else is correctly adjusted. Strobe timing is not necessary. The ignition will advance as per the pre-programmed curve (see advance graph).

Installation is now complete.

FIG. 2

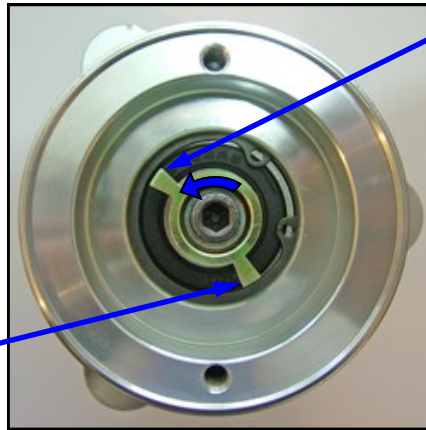

**T.D.C. REFERENCE
(REAR CYLINDER)**

**T.D.C. REFERENCE
(FRONT CYLINDER)**

**Steel timing rotor
secured with fixing screw/washer
Installed into magneto replacement housing**

FIG. 3

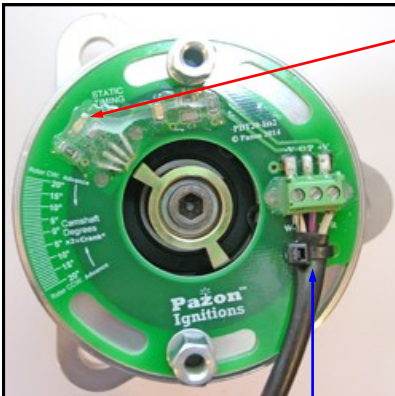

Static timing led

**Trigger assembly fitted
into housing,
with hex pillar
fixings & washers**

Pillar fixings loosely fastened

WHITE-BLACK , VIOLET-RED, WHITE-RED

**PLEASE NOTE: MAGNETO REPLACEMENT HOUSING ORIENTATION
MAY BE DIFFERENT TO THAT SHOWN IN THESE PICTURES**

STATIC IGNITION TIMING
REAR PISTON AT T.D.C.
COUNTER-CLOCKWISE TIMING ROTOR ROTATION

FIG. 4

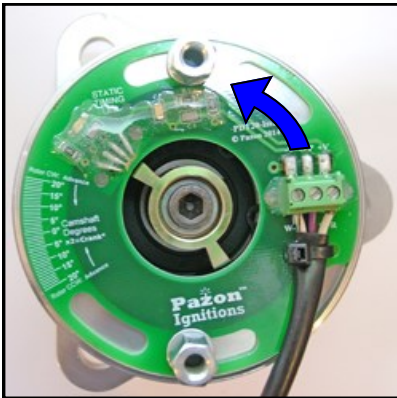

Rotate trigger assembly fully counter-clockwise

FIG. 5

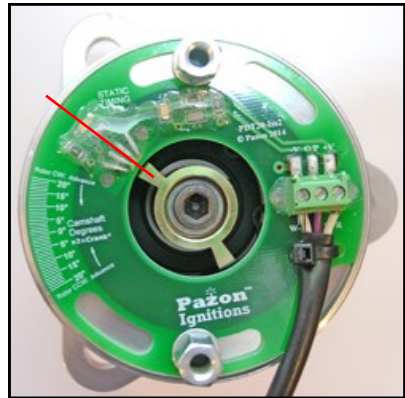

**Rear piston @ TDC on compression stroke,
Align centre of rotor tab with static timing lead,
tighten rotor cap head screw**

SWITCH IGNITION ON

FIG. 6

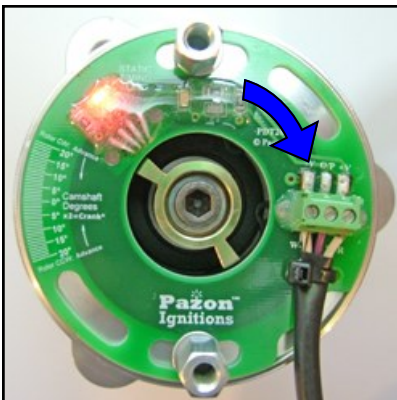

**Rotate trigger very slowly
CLOCKWISE
until red static timing led
turns ON
STOP ROTATING
TIGHTEN PILLAR FIXINGS**

REV-LIMITER

USE OF THIS FUNCTION IS AT YOUR OWN RISK, SINCE IT IS POSSIBLE TO SET THE REV-LIMITER TO BEYOND THE DESIGNED UPPER RPM LIMIT FOR YOUR ENGINE.

The **Smart-Fire** ignition module features a function button that enables the user to set/reset the ignition rev-limiter. Unless specified when purchasing the system, the rev-limiter is not preset, allowing your engine to rev to its maximum (unrestricted).

To Set the Rev-Limiter

To accurately set the rev-limiter you will need a rev-counter/tachometer to monitor the engine rpm. Rev the engine to one-half the desired rev-limit rpm, press & hold the function button for a minimum of 3 seconds. The ignition module will take a snapshot of the engine rpm at the instant the button is pressed, therefore it is not essential to maintain a precise rpm whilst the button is pressed. The yellow indicator led on the module will flash 5 times. Release the button. The rev-limiter is now set. When your engine reaches the preset rpm the ignition will turn off the ignition coil, cutting all sparks. Thus, the engine rpm will fall and, once below the rev-limit setting, ignition will resume.

The minimum rev-limiter setting is 3000 rpm (i.e. set with the engine running at 1500 rpm).

To Reset the Rev-Limiter

To reset (disable) the ignition rev-limiter, press & hold the function button for a minimum of 3 seconds, with the engine below 1500 rpm (or stationary). The yellow indicator led on the module will flash 5 times. Release the button. The rev-limiter is now reset.

The rev-limiter setting is retained in the ignition module memory & will be recalled when the ignition is turned on.

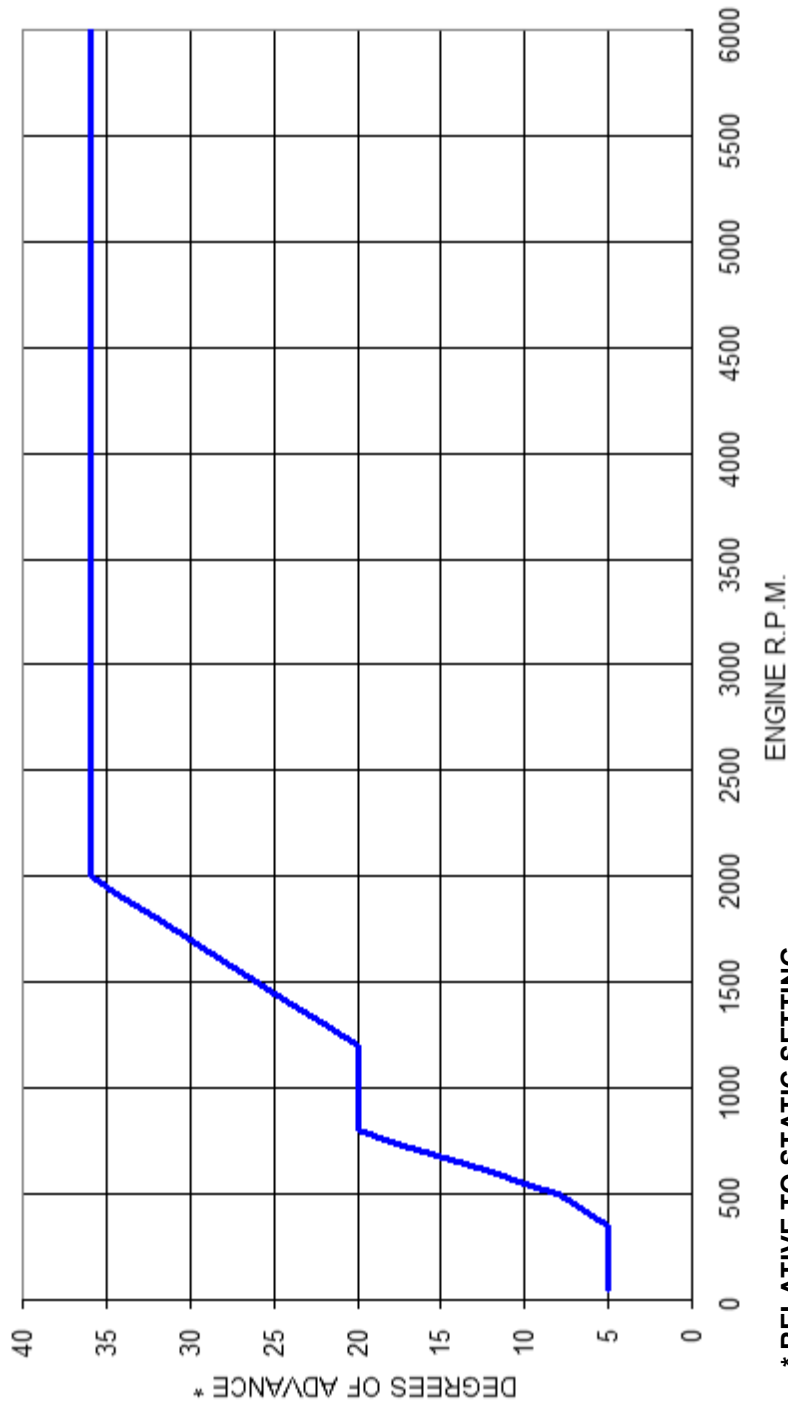

* RELATIVE TO STATIC SETTING

MAP001

Terms & Conditions and Warranty

- Use of this product indicates your acceptance of this notice.
- The product design, firmware & literature is Copyright © PAZON IGNITIONS LTD. 2005-2024, and is protected under international copyright, trademark & treaty provisions.
- To provide the best ignition systems possible, Pazon Ignitions Ltd. reserves the right to alter and improve the specifications of its products without prior notice.

Ignition Systems

- Pazon Ignitions warrants to the original purchaser that the Pazon Ignition System be free from defects in workmanship & parts under normal use for a period of 7½ years from date of purchase.

Ignition Spares

- Spares are defined as item(s) not purchased as part of a complete ignition system. Pazon Ignitions warrants to the original purchaser that these item(s) be free from defects in workmanship & parts under normal use for a period of one year from date of purchase.
- Ignition coils will only be covered by the warranty if it can be proved that the fault is due to a manufacturing fault within the coil.

Limitation of Liability

- In no event shall Pazon Ignitions' liability related to the product exceed the purchase price actually paid for the product.
- Neither PAZON nor its suppliers shall in any event be liable for any damages whatsoever arising out of or related to the use or inability to use the product, including but not limited to the direct, indirect, special, incidental or consequential damages, or other pecuniary loss.
- This warranty will be void if the product or parts have been altered, damaged, abused or installed incorrectly.
- This warranty will be void if parts supplied by Pazon Ignitions are used with other makes of ignition. Your statutory rights are not affected.

Warranty Claims

- To make a claim under warranty, the product must be returned to Pazon Ignitions or its authorized representative, with a copy of your receipt (or evidence of date and place of purchase), within the warranty period.
- Include a detailed description of the problem and why you believe there is a fault within the ignition system.
- The system must be returned postage paid. Proof of posting is not proof or receipt, therefore we recommend using a recorded mail service.
- Upon receipt we will thoroughly test the returned items and repair or replace any items found to be faulty and covered by the warranty.
- Please allow seven working days from receipt of the returned parts before contacting us, to allow sufficient time for a thorough test and evaluation.
- PLEASE CONTACT PAZON IGNITIONS FOR RETURN INSTRUCTIONS.

✉ **Pazon Ignitions Ltd, 274 Hot Springs Road, RD 2,
Katikati 3178, Bay of Plenty, New Zealand**

☎ **TELEPHONE: +64 (0) 7549 5878** 📠 **FAX: +64 (0) 7549 5879**
EMAIL: ignition@pazon.com WEB: www.pazon.com